

# Champro®



## 5-SHELF BOLTLESS SHELVING UNITS

MODEL NO: CS5265S, CS5265RP & CS5265BP

PART NO: 6600640, 6600645 & 6600650

## ASSEMBLY INSTRUCTIONS



GC0115

---

## **INTRODUCTION**

---

Thank you for purchasing this CLARKE product.

Before attempting to use this product, please read this manual thoroughly and follow the instructions carefully. In doing so you will ensure the safety of yourself and that of others around you, and you can look forward to your purchase giving you long and satisfactory service.

---

## **GUARANTEE**

---

This product is guaranteed against faulty manufacture for a period of 12 months from the date of purchase. Please keep your receipt which will be required as proof of purchase.

This guarantee is invalid if the product is found to have been abused or tampered with in any way, or not used for the purpose for which it was intended.

Faulty goods should be returned to their place of purchase, no product can be returned to us without prior permission. This guarantee does not effect your statutory rights.

---

## **GENERAL SAFETY RULES**

---

1. Always maintain the equipment in good condition for the best/safest performance.
2. Never exceed the maximum load for these units.
3. Never use these units if they are damaged.
4. Always load small, stable items on the top shelves, heavier and bulky items should be stored on the lower shelves.

Please keep these instructions in a safe place for future reference.

---

## **ENVIRONMENTAL PROTECTION**

---

Do not dispose of this product or damaged parts with general household waste. All tools, accessories and packaging no longer required should be sorted, taken to a recycling centre and disposed of appropriately.

# INVENTORY

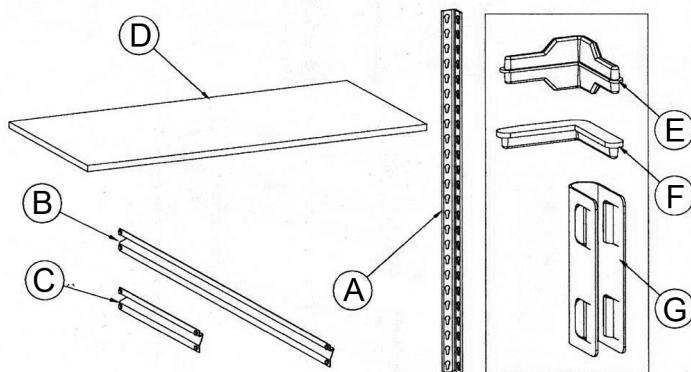

No	Description	Quantity
A	Corner Post	8
B	Long Beam	10
C	Short Beam	10
D	Shelf	5
E	Post Insert	4
F	End Cap	8
G	Corner Post Joining Clip	2

## ASSEMBLY ADVICE

1. Assemble on a strong, level surface. Avoid assembly on a domestic carpet.
2. Use a cloth or softwood block to protect the surface finish of the product when using a mallet. Strike the flat surface of each beam to prevent damage to the beam.
3. Always ensure that the rivets sit at the bottom of the keyhole slots.
4. It is recommended that the assembly should be done by two persons.
5. The shelving unit is not recommended for outdoor use.

# ASSEMBLY INSTRUCTIONS

## TOOLS REQUIRED

Rubber mallet or hammer

Protective cloth/wood block

## OPTION 1 - ASSEMBLED AS STORAGE RACKING

1. The storage racking configuration is shown in Fig 1.



Fig 1

2. Create an end assembly by fitting a short beam (C) into the lowest keyholes of two corner posts (A).
  - Drive the rivets to the bottom of the keyholes by tapping the beam near the joint with a rubber mallet to lock the pieces together. Use a cloth or softwood block to protect the surface finish.
  - Ensure all beams are installed with the flat (shelf-bearing) surface uppermost.
3. Create a second end assembly.
4. Join the two end assemblies together with two long beams (B) as in Fig 3.

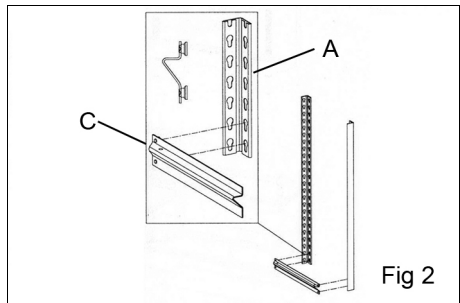

Fig 2

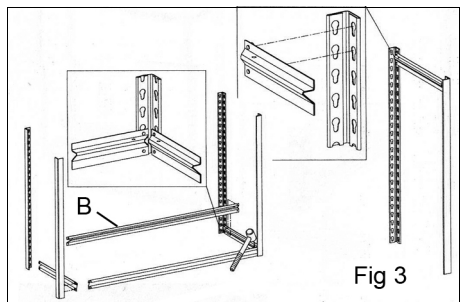
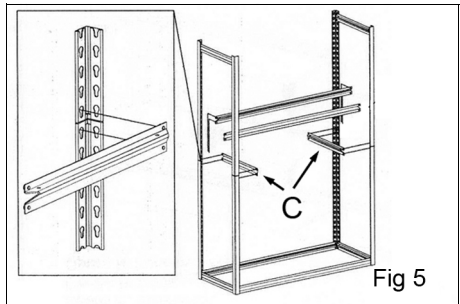
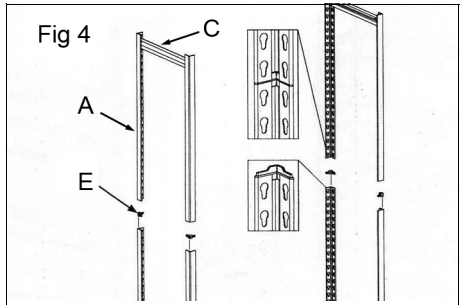
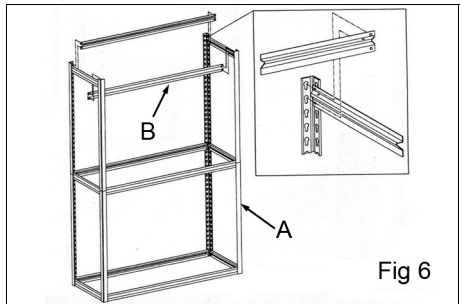

Fig 3

5. Use a short beam (C) in the top holes to join two corner posts and create an upper end assembly as shown in Fig 4.
  6. Repeat for the opposite upper end assembly.
  7. Fit post inserts (E) into the corner posts (A) of the lower assembly.
  8. Fit both upper end assemblies onto the post inserts (E).
  9. Use a short beam (C) to join the upper and lower assemblies together at each end as shown in Fig 5. Repeat with the long beams at each side.
- The beams must span the upper and lower assemblies.



10. Add long beams (B) to the top keyholes of the corner posts (A) as shown in Fig 6.



11. Connect the remaining beams as required to create two additional shelves.
12. Lay the shelf panels (D) into position.
13. Insert the post caps (F) into the top of each corner post (A).

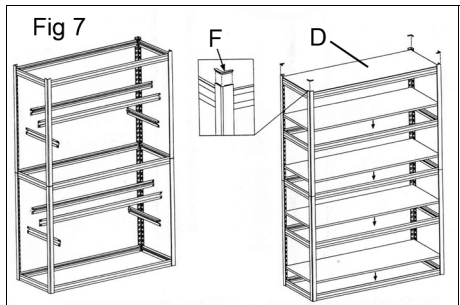

## OPTION 2 - ASSEMBLED AS A WORKBENCH

1. An alternative workbench configuration is shown in Fig 8.
- The two units can be used as free-standing benches or joined together, in-line or at right angles.

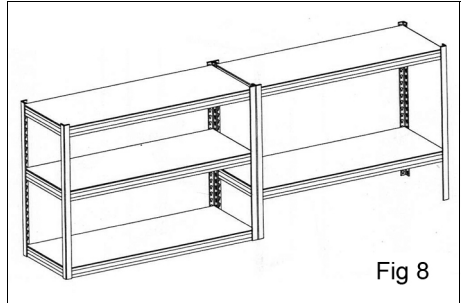

Fig 8

2. Create two end frame assemblies and join together using the steps on page 4.
3. Add additional beams to create a center shelf at the required level as in Fig 9.

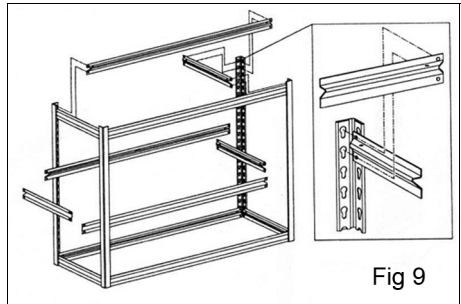

Fig 9

4. Assemble the second unit with the lower beams typically installed at the 7th/8th keyholes from the bottom as shown in Fig 10.

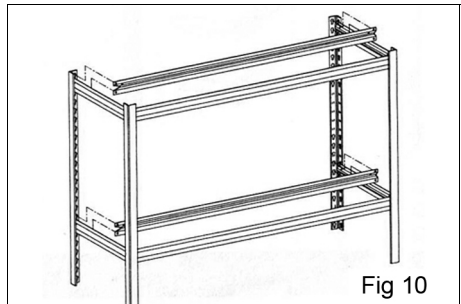

Fig 10

5. Complete the second bench as shown in Fig 11.
6. Lay the shelves (D) in position.

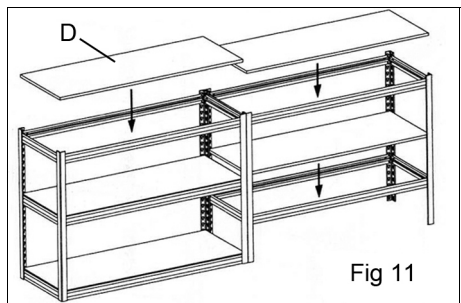
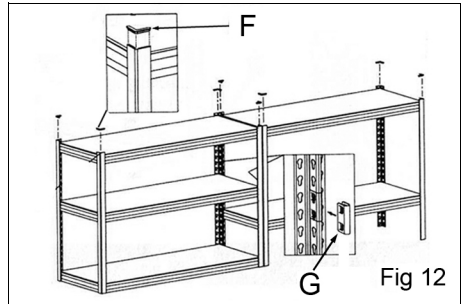

Fig 11

7. Insert the post caps (F) to the top of the corner posts.
8. To connect the bench units draw the assemblies together and use Post Joining Clips (G) to tightly clamp the corner posts together.
  - A screwdriver can be used to prize off the clips if required.



## SPECIFICATION

Dimensions (W x D x H)	Shelving Unit 1220 x 460 x 1830 mm Workbench 2440 x 460 x 915 mm
Weight (Empty)	31 kg
Maximum Rated Load	265 kg per shelf (evenly distributed)

# A SELECTION FROM THE VAST RANGE OF

# Clarke®

## QUALITY PRODUCTS

### AIR COMPRESSORS

From DIY to industrial, Plus air tools, spray guns and accessories.

### GENERATORS

Prime duty or emergency standby for business, home and leisure.

### POWER WASHERS

Hot and cold, electric and engine driven - we have what you need

### WELDERS

Mig, Arc, Tig and Spot. From DIY to auto/industrial.

### METALWORKING

Drills, grinders and saws for DIY and professional use.

### WOODWORKING

Saws, sanders, lathes, mortisers and dust extraction.

### HYDRAULICS

Cranes, body repair kits, transmission jacks for all types of workshop use.

### WATER PUMPS

Submersible, electric and engine driven for DIY, agriculture and industry.

### POWER TOOLS

Angle grinders, cordless drill sets, saws and sanders.

### STARTERS/CHARGERS

All sizes for car and commercial use.



**PARTS & SERVICE: 0208 988 7400**

**E-mail: [Parts@clarkeinternational.com](mailto:Parts@clarkeinternational.com) or [Service@clarkeinternational.com](mailto:Service@clarkeinternational.com)**

**SALES: UK 01992 565333 or Export 00 44 (0)1992 565335**

**Clarke®** INTERNATIONAL Hemnall Street, Epping, Essex CM16 4LG  
[www.clarkeinternational.com](http://www.clarkeinternational.com)